

# Fault Injection Framework for Fault Diagnosis based on Machine Learning in Heating and Demand-Controlled Ventilation Systems

Ali Behravan, Roman Obermaisser, Deepak Hanike  
Basavegowda  
Institute of Embedded Systems  
University of Siegen  
Siegen, Germany  
Ali.behravan@uni-siegen.de  
Roman.obermaisser@uni-siegen.de  
Deepak.hbasavegowda@student.uni-siegen.de

Ahlam Mallak, Christian Weber, Madjid Fathi  
Institute of Knowledge-Based Systems and Knowledge  
Management  
University of Siegen  
Siegen, Germany  
Ahlam.mallak@uni-siegen.de  
Christian.weber@uni-siegen.de  
Fathi@informatik.uni-siegen.de

**Abstract**— The main purpose of a heating, ventilation and air-conditioning system is to provide thermal comfort and acceptable indoor air quality through adequate natural ventilation by exchanging the building zone air with the outside fresh air, as an option. This air exchange during the cold seasons can be considered as a heating load for the heating system which increases the energy consumption of the heating system. The use of the demand-controlled ventilation system can be counted as a potential energy saving method by its automatic adjustment of ventilation, which modifies the amount of fresh air coming from outside and causes less energy consumption by less heating load, as a result. Faults in system components such as sensors and actuators can result in different types of failures and severe implications on the efficiency of the heating and demand-controlled ventilation system. However, tracing the component and system behavior back to the faults is a challenging task. This study demonstrates a successful approach for finding the nature, value, time of occurrence, and locality of these faults using a mapping from failures to faults with knowledge-based diagnostic techniques. We introduce fault models for online diagnosis using machine learning. These fault models are established for a heating and demand-controlled ventilation system with fault injection blocks design using a simulation framework based on MATLAB/Simulink.

**Keywords**—Demand-Controlled Ventilation; heating modeling and simulation; MATLAB/Simulink; fault injection; failure; fault detection and diagnosis; machine learning

## I. INTRODUCTION

Heating, ventilation and air conditioning (HVAC) systems keep the thermal conditions in a comfort zone and indoor air quality in an acceptable range. HVAC systems are one of the largest consumers of energy, especially in office buildings [1]. Statistical data shows that the energy consumption can be

divided into different categories in commercial buildings where the contributions for space heating and ventilation are 16% and 9.1%, respectively [2, 3]. These statements demonstrate the potential of energy saving which exists in the building sector. Furthermore, carbon dioxide (CO<sub>2</sub>) proliferation in office spaces due to human respiration can cause some negative characteristics for occupant comfort, e.g. feeling unwell, lack of concentration, and deterioration in efficiency.

Natural ventilation is an effective method to improve indoor air quality (IAQ) and to dilute indoor CO<sub>2</sub> concentration in offices. Most codes and standards specify some constants for required air change volume per person or per area for different places, which can lead to over ventilation and increased energy consumption, or underventilation that leads to an uncomfortable environment for occupants in some cases [4], while demand-controlled ventilation (DCV) increases the potential energy saving in heating systems by preventing excessive outside low-temperature air to come into the building spaces.

DCV is a control strategy that modifies the amount of fresh air coming from the outside environment delivered to a room by automatic adjustment of economizer damper actuators based on the CO<sub>2</sub> sensor measurements and other parameters such as inside temperature and occupants. Studies demonstrate that 15% to 25% of the HVAC system's energy can be saved by setting the ventilation rates based on the occupants' fresh air requirement [5]. This is an example of energy saving strategies in buildings, especially in offices.

DCV systems have become complex systems with hundreds of sensors and actuators in a typical office building. Faults affecting these components are therefore common events and engineers need to devise strategies for fault recovery in order to provide an acceptable level of services despite different types of faults. The key aspect is the identification of nature and

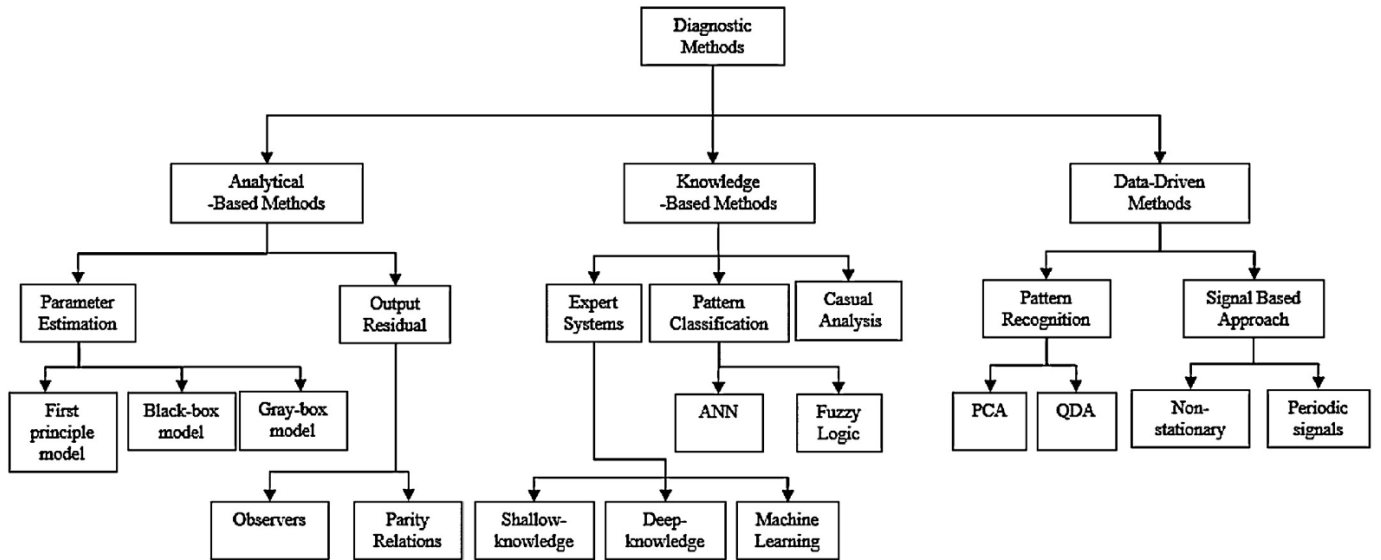

Fig. 1. Generic diagnostic techniques.

locality of the fault using diagnostic techniques in order to decide on the appropriate recovery action. The establishment of diagnostic models with an accurate mapping between observed component behaviors, failures, and faults is a time consuming and error-prone task.

A fault is an unpermitted deviation of at least one characteristic property of the system from its normal, acceptable, usual and expected behavior [6]. A fault may trigger a failure or a malfunction of the system if it is not detected, contained and masked by fault-tolerance mechanisms. A failure is a permanent interruption of a system's ability to perform a required function under specified operating conditions which result from one or more faults. Several problems such as system failure or performance degradation can arise due to faults in components, e.g. sensors and actuators.

A survey of faults in HVAC systems has been performed as part of the international energy agency's annex 25 [7]. The faults can be categorized as design faults, installation faults, abrupt faults, and degradation faults. Examples are sensor faults such as wrong sensor readings or noisy sensors, and actuator faults such as a stuck-at fault. These faults waste more than 20% of the energy consumed by HVAC systems, cause unnecessary CO<sub>2</sub> emissions and decrease occupant thermal comfort, as well as reducing productivity [8, 9]. Basarkar et al. reported that the presence of HVAC faults can influence the total HVAC energy use by as much as 22%, depending on the type of faulty behavior and the severity of the faults [10].

Based on the National Institute of Standards and Technology (NIST), fault detection and diagnosis (FDD) methods have a potential of 10% to 40% energy savings in HVAC systems [11]. Studies have indicated that 20% to 30% energy savings are achievable by re-commissioning HVAC systems to rectify faulty operation [12]. For example, a stuck damper can cause significant heating, cooling, comfort, and energy consumption issues depending on which position the damper is stuck at. Lee et al. documented the energy penalty associated with various air-side system faults. There is a report of 36% excess cooling energy consumption due to a single VAV box damper being stuck open [13].

Katimapula et al. found that poorly maintained, degraded and improperly controlled equipment wastes an estimated 15% to 30% of energy in commercial buildings [14]. Around 15% to 30% of the energy loss in buildings is due to the performance degradation, improper control strategy, and malfunctions of HVAC systems [15]. In a survey of UK buildings, the data

showed 25–50% of energy wasted from faults in building HVAC systems. This range could be reduced below 15% whenever those faults could be detected and identified early in the premature stage before unacceptable damages occur [16]. Zhou et al. described that it is necessary to implement the fault detection and diagnosis methods for HVAC systems to keep them working properly for energy saving, life-prolonging, and indoor air quality enhancement [15]. Therefore, there is a great potential to develop a reliable fault detection and diagnosis tool to guarantee the normal operation of HVAC and DCV systems which causes better energy efficiency.

This paper provides a solution for partly automatizing this activity using machine learning and fault injection framework. During development time, faults that shall be identified are intentionally injected into a simulation of the HVAC systems and machine learning algorithms establish the mapping to the ensuing component behaviors. Later, at runtime, the established diagnostic models can be used in the opposite manner by concluding on faults based on observed component behaviors and failures.

## II. GENERIC DIAGNOSTIC TECHNIQUES

Different methods were deployed for fault detection and diagnosis for these complex systems in last years. Yu et al. considered energy consumption as a useful parameter to detect faults using the Fuzzy Neural Networks (FNN) model [17]. Sterling et al. compared two model-based diagnostic solutions of qualitative and quantitative models and encoded failure modes in their Modelica model [18]. The simulation is a helpful operation platform to develop and test fault detection and diagnosis strategies for component-level or system-level faults. Basarkar et al. identified, characterized and prioritized common faults of HVAC equipment and control systems in the EnergyPlus building performance simulation tool, but the EnergyPlus tool has limited capability of modeling HVAC faults [10].

Generally, modified fault diagnostic techniques can be reported in figure 1 which is reported by Katipamula and Brambley [19, 20].

## III. FAULT DETECTION AND DIAGNOSIS

Fault detection and diagnosis is an area of investigation concerned with automating the process of detecting faults in a physical system and diagnosis their causes. The primary

objective of an FDD system is the early detection of faults and diagnosis of their causes, enabling correction of the faults before additional damage to the system or loss of service occurs [21].

In HVAC systems, fault detection is the determination that the operation of the building is incorrect or unacceptable in some respect. Unacceptable behavior may occur over the whole operating range or be confined to a limited region and hence only occur at certain times. For large-scale systems, if information, relating to generating mathematical models, are not available or are too costly and time-consuming, knowledge-based methods are alternative approaches to solve these problems for fault diagnosis. These techniques are based on qualitative models that can be generally obtained through causal modeling or detailed description of systems, expert knowledge, or typical fault symptoms [22]. The procedure of FDD can consist of an existing expert knowledge, an inference engine, or an expert system interface which can combine with the knowledge from first principles or structural description of the system in terms of rules. Meanwhile, an expert systems approach can be classified into shallow-knowledge expert systems using the formulation of IF-THEN rules for generating rule-based methods; deep-knowledge expert systems including functional reasoning or first-principles expert systems for diagnosing faults, and machine learning methods [23]. However, expert approaches are difficult to design when knowledge acquisitions of experts and collecting of real cases are not available. A possible solution to solve this problem is to use a machine learning approach, through which knowledge is automatically extracted from data by using advanced statistical theories such as hidden Markov model (HMM) and Kernel machines [24] but also other methods as neuronal networks.

#### A. Machine learning techniques for heating systems optimization

The use of simulation tools for heating systems is not new. It has been widely utilized for analyzing and tracking energy consumption and control, due to its simplicity and efficiency in designing the building models and tracking all inputs and outputs of this model at any given point of time. Thus, applying simulation tools for heating systems can offer a very accurate representation of the actual measurements [25]. What also is worth to be mentioned is the feasibility and freedom that the simulation tools give in experimenting with different parameters and injecting different faults to the designed system, which is difficult to achieve in real practice scenarios [26].

Applying machine learning and statistical techniques to detect and diagnose the faults in different building models, played a crucial role in drawing researchers' attention to heating system design and control lately. Using machine learning in such models makes FDD a lot easier and faster, and optimizes the energy consumption in the building model, based on deriving hidden patterns between different components in the building model, using an accurate and intensive learning techniques which have been adequately trained and thoroughly tested, as addressed in [9].

The machine learning focuses on system behavior pattern instead of residuals. In other words, instead of diagnosing the system health status through comparing its outputs directly with model predictions (or other references), diagnosis can be done by analyzing system behavior over a window of operation [27]. Therefore, integrating machine learning in demand-controlled ventilation and heating systems has been a prominent topic for research and industrial application recently.

In this work, our main focus is to conceptualize an active diagnosis learning model for the embedded components, such as sensors and actuators, and their associated faults, in the designed office building model at any given point of time during the day, based on intensive and comprehensive learning of the simulated heating system behavior.

### IV. SYSTEM ARCHITECTURE

In this section, the architecture of the overall system is presented, which shows the overview of this work. Figure 2 shows the workflow and architecture of the system, represented by its main steps as below: 1) Fault injection to the simulated model. 2) Data collection and extraction from the simulation. 3) Create the learning model based on the extracted data. 4) Run the learning model consistently, given the captured values for the model component and physical parameters at this point of time, to provide an active diagnosis for the faulty parts if any. These steps are described in details at the following sub-sections.

#### A. Fault Injection to the Simulated Model

For the implementation, test, and development of FDD methods, a framework, including a model and simulation tool for fault injection, or faulty and healthy data are needed. Behravan et al. modeled and simulated a thermal dynamic heating system for a multi-zone office building equipped with demand-controlled ventilation using MATLAB/Simulink [28].

This paper presents a fault injection model which is simulated by MATLAB/Simulink version R2017a, using the Simscape toolbox. Different types of faults are modeled, simulated, and injected into the Simulink model which is based on the mentioned model for monitoring system responses in different faulty and fault-free (healthy) modes of system operation, and the application of machine learning techniques for fault detection and diagnosis for this framework is conceptualized. The model contains six office rooms and one corridor, based on the real dimensions and thermal specifications of a building at the University of Siegen, Germany, during a typical winter day in February. Figure 3 shows the office building sketch.

The model dynamics consist of various governing equations and coefficients for heat transfer effects of different zones of the building on each other, as well as the ventilation which is affected by outdoor wind, Buoyancy phenomena, and indoor/outdoor temperature can be found in reference [28].

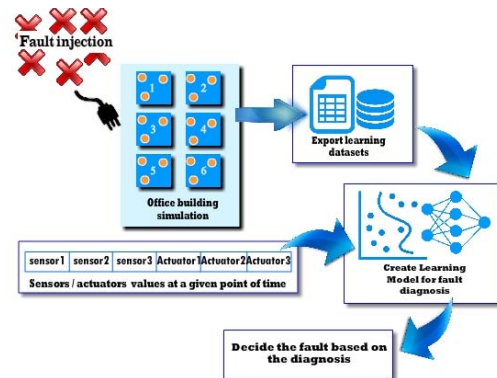

Fig. 2. Conceptual workflow for the learning and diagnosis of faults.

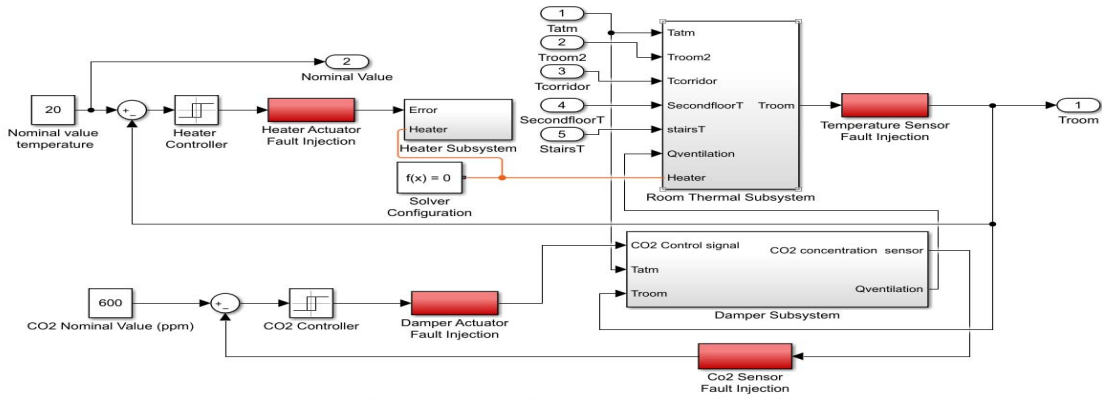

Fig. 4. Simulink model of an office room with fault injection blocks.

Figure 4 demonstrates the Simulink model for one room which is equipped with four fault injection blocks (subsystems) that are highlighted in red color. The occupancy in each room was simulated as an occupancy pattern which determines the number of persons. Each room has one temperature sensor, one CO<sub>2</sub> concentration sensor, one occupancy sensor, one economizer damper actuator which is coupled to a damper, one heater actuator that is coupled to the heater (thermostat), and one fault injection dashboard to manually inject the fault into the system.

The demand-controlled ventilation system can control the position of the damper (open/close) and the heater actuator can control the status of the heater (on/off). The dashboard consists of four fault cases for the CO<sub>2</sub> sensor, economizer damper actuator, temperature sensor, and heater actuator (thermostat), which can be activated in the model. Figure 5 belongs to the CO<sub>2</sub> sensor fault injection case that describes a continuous wrong sensor reading with a constant value of 700 ppm for indoor CO<sub>2</sub> concentration or noisy fault values within the range of 550 ppm to 750 ppm, using the switch block. Figure 6 shows this switch model. The fault case of a damper actuator describes a stuck damper in a closed position and as a result, the indoor air temperature is increased and the CO<sub>2</sub> concentration goes above the maximum permitted threshold. The fault case of a temperature sensor describes wrong sensor readings with a constant value of 15°C, and the fault case of the heater actuator describes a stuck-at fault in the heating mode. The corridor subsystem consists of two fault cases because there is no CO<sub>2</sub> sensor and no economizer damper.

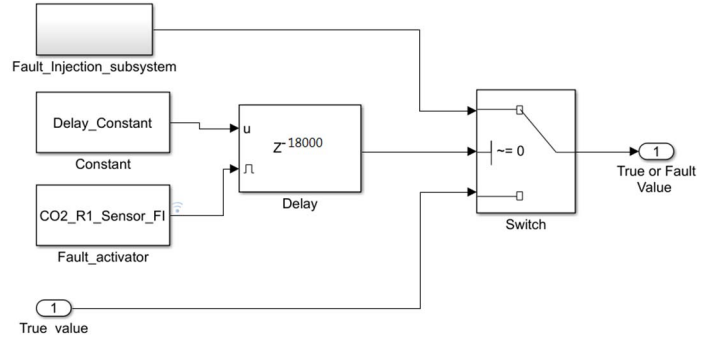

Fig. 5. Simulink model for Fault injection inside CO<sub>2</sub> sensor fault injection.

### B. Data Collection and Extraction from the Simulation

The fault detection and diagnosis part is based on the data that is extensively collected to the data sets from the created demand-controlled ventilation and heat system model with fault injection. The sampling interval for the collected data is one second. Parameters of interest for each office room are measured: the outside and inside temperature, inside CO<sub>2</sub> concentration, occupancy, heater status, and economizer damper status.

The behavior of the system in the healthy mode of operation and in presence of faults can be studied by activating faults (fault injection) and the effects can be monitored. Data in healthy and faulty modes are captured in a database from the simulation. Table 1 shows a sample of captured data in five seconds of simulation for four types of faults in room one. Table 2 shows the variable changes if a CO<sub>2</sub> sensor fault is being injected into the system, and Table 3 indicates the effect of fault injection of a room on the other rooms.

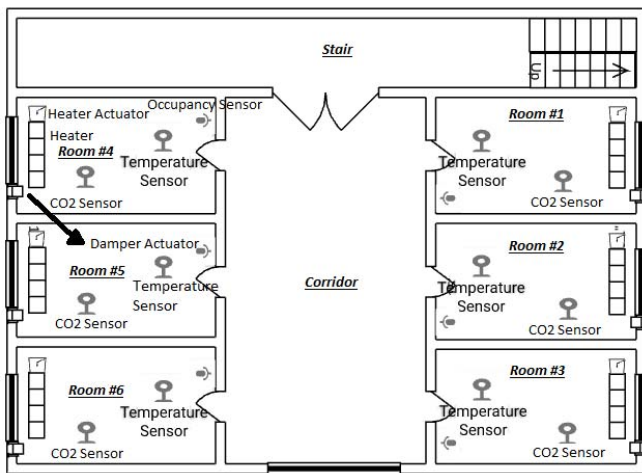

Fig. 3. Office building sketch for the model.

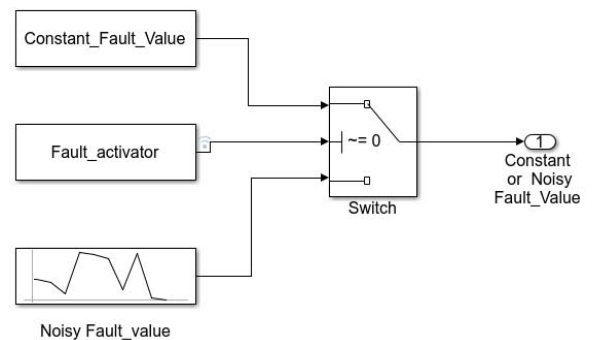

Fig. 6. Switch for noisy or constant value fault injection.

Table 1. Example of captured data of room one, in presence of different fault modes

Simulation Variables			Room #1																							
			Healthy Values				CO <sub>2</sub> Sensor Fault Values				Damper Actuator Fault Values				Temperature Sensor Fault Values				Heater Actuator Fault Values							
Time (seconds)	Outside Temp (°C)	Occupants	Temp (°C)	Heater status	Co <sub>2</sub> Value (PPM)	Damper status	Temp (°C)	Heater status	Co <sub>2</sub> Value (PPM)	Damper status	Temp (°C)	Heater status	Co <sub>2</sub> Value (PPM)	Damper status	Temp (°C)	Heater status	Co <sub>2</sub> Value (PPM)	Damper status	Temp (°C)	Heater status	Co <sub>2</sub> Value (PPM)	Damper status				
17998	11.82934669	6	19.62564615	1	583.730057	1	19.62564615	1	583.730057	1	19.62564615	1	583.730057	1	19.62564615	1	583.730057	1	19.62564615	1	583.730057	1	19.62564615	1		
17999	11.82944086	6	19.62383768	1	583.6254609	1	19.62383768	1	583.625461	1	19.6238377	1	583.625461	1	19.62383768	1	583.6254609	1	19.6238377	1	583.6254609	1	19.6238377	1	583.6254609	1
18000	11.82953501	6	19.62204271	1	583.5210898	1	19.62204271	1	583.52109	1	19.6220427	1	583.52109	1	19.62204271	1	583.5210898	1	19.6220427	1	583.5210898	1	19.6220427	1	583.5210898	1
18001	11.82962913	6	19.62026115	1	583.4169432	1	19.62026115	1	700	1	19.6202611	1	583.416943	1	15	1	583.4169432	1	19.6202611	1	583.4169432	1	19.6202611	1	583.4169432	1
18002	11.82972323	2	19.61849288	1	583.1283827	1	19.61849288	1	700	1	19.6184929	1	583.128383	1	15	1	583.1527961	1	19.6184929	1	583.1283827	1	19.6184929	1	583.1283827	1
18003	11.8298173	2	19.61673781	1	582.8408643	1	19.61673781	1	700	1	19.6167378	1	582.840864	1	15	1	582.889767	1	19.6167378	1	582.8408643	1	19.6167378	1	582.8408643	1

Table 2. Example of captured data of healthy variables in other rooms

Variables			Healthy Mode of the Total System																							
			Room #2				Room #3				Room #4				Room #5				Room #6							
Time (seconds)	Outside Temp (°C)	Occupants	Temp (°C)	Heater status	Co <sub>2</sub> Value (PPM)	Damper status	Temp (°C)	Heater status	Co <sub>2</sub> Value (PPM)	Damper status	Temp (°C)	Heater status	Co <sub>2</sub> Value (PPM)	Damper status	Temp (°C)	Heater status	Co <sub>2</sub> Value (PPM)	Damper status	Temp (°C)	Heater status	Co <sub>2</sub> Value (PPM)	Damper status				
18136	11.84210093	2	19.1591807	1	564.7195257	1	19.44525371	1	550.7150426	0	19.5027828	1	550.1011416	0	19.1591807	1	564.7195257	1	19.44525371	1	550.7150426	0	19.5027828	1	550.1011416	0
18137	11.84219158	2	19.16318835	1	564.4718098	1	19.45771577	1	550.8073393	0	19.51586799	1	550.1934384	0	19.16318835	1	564.4718098	1	19.45771577	1	550.8073393	0	19.51586799	1	550.1934384	0
18138	11.84228219	2	19.16719061	1	564.2245897	1	19.4701353	1	550.8996361	0	19.52890786	1	550.2857351	0	19.16719061	1	564.2245897	1	19.4701353	1	550.8996361	0	19.52890786	1	550.2857351	0
18139	11.84237279	2	19.17118746	1	563.9778645	1	19.48251247	1	550.9919329	0	19.54190259	1	550.3780319	0	19.17118746	1	563.9778645	1	19.48251247	1	550.9919329	0	19.54190259	1	550.3780319	0
18140	11.84246335	2	19.17517885	1	563.7316333	1	19.49484744	1	551.0842297	0	19.55485235	1	550.4703287	0	19.17517885	1	563.7316333	1	19.49484744	1	551.0842297	0	19.55485235	1	550.4703287	0

Table 3. Example of captured data of the effect of CO<sub>2</sub> sensor fault in room one on the variables of other rooms

Variables			Room #1																							
			Room #2				Room #3				Room #4				Room #5				Room #6							
Time (seconds)	Outside Temp (°C)	Occupants	Temp (°C)	Heater status	Co <sub>2</sub> Value (PPM)	Damper status	Temp (°C)	Heater status	Co <sub>2</sub> Value (PPM)	Damper status	Temp (°C)	Heater status	Co <sub>2</sub> Value (PPM)	Damper status	Temp (°C)	Heater status	Co <sub>2</sub> Value (PPM)	Damper status	Temp (°C)	Heater status	Co <sub>2</sub> Value (PPM)	Damper status				
18136	11.84210093	2	19.1591807	1	564.7195257	1	19.44525371	1	550.7150426	0	19.5027828	1	550.1011416	0	19.1591807	1	564.7195257	1	19.44525371	1	550.7150426	0	19.5027828	1	550.1011416	0
18137	11.84219158	2	19.16318835	1	564.4718098	1	19.45771577	1	550.8073393	0	19.51586799	1	550.1934384	0	19.16318835	1	564.4718098	1	19.45771577	1	550.8073393	0	19.51586799	1	550.1934384	0
18138	11.84228219	2	19.16719061	1	564.2245897	1	19.4701353	1	550.8996361	0	19.52890786	1	550.2857351	0	19.16719061	1	564.2245897	1	19.4701353	1	550.8996361	0	19.52890786	1	550.2857351	0
18139	11.84237279	2	19.17118746	1	563.9778645	1	19.48251247	1	550.9919329	0	19.54190259	1	550.3780319	0	19.17118746	1	563.9778645	1	19.48251247	1	550.9919329	0	19.54190259	1	550.3780319	0
18140	11.84246335	2	19.17507146	1	563.7316334	1	19.49484728	1	551.0842297	0	19.55485229	1	550.4703287	0	19.17517879	1	563.7316333	1	19.49484738	1	551.0842297	0	19.55485229	1	550.4703287	0

### C. Create the Learning Model based on the Collected Data

Machine learning is a methodology for finding hidden patterns in data that leads to major conclusions [29]. Moreover, machine learning is considered a part of computer science and a subfield of artificial intelligence. The core of the machine learning idea is to create algorithms that are used to construct learning models, which can eventually make decisions and data-driven predictions.

As mentioned earlier in this paper, the concept of machine learning for heating systems with demand-controlled ventilation is studied to achieve an active diagnosis for a heating system, applied in an office building at run-time using machine learning methods. In contrast to well-studied problem domains as image processing, best practices for applying machine learning solutions in FDD applications are still scarce. Considering the variety of FDD problems, systems and factors, a possible machine learning solution has to be individually selected, tailored and evaluated. In this regard, this short-study sheds light especially on the selection process and data considerations to lay the foundation for a future tailoring and evaluation study, with a selection and pre-processing workflow.

In this section, we highlight requirements and describe the learning approach step by step and conceptualized for this diagnostic system, which includes: data preparation and preprocessing, examine and compare different machine learning algorithms and optimize the best-chosen machine learning algorithms.

#### 1) Data Preparation and Preprocessing

This process is for converting the raw data, extracted from the simulation model into a form of data that is compatible with the machine learning application.

Machine learning algorithms learn from data, so it is essential to use the right data for solving the problem of interest. Independent of the data quality, it is needed to make sure that the data is in the right format, correctly scaled and including the features which are describing the use case.

The data preparation process to get the data ready for the learning consist of three important steps [30]:

- **Data Selection:** this step focuses on studying the available data, and considers what is missing and what has to be added, or what is unnecessary and must be removed.
- **Data Preprocessing:** preprocessing the data means making the proper changes on the selected data to make it ready to be fed in the machine learning model, that includes data sampling, data cleaning, and data formatting.
- **Data Transformation:** the final step requires more sophisticated techniques for features engineering, like attribute decomposition, aggregation, and scaling.

Data preparing is a diverse topic that can take a long time and effort in exploring and analyzing the data even before starting the learning process. The main goal of this process is to represent the raw data in a much clearer and useful representation of the problem of interest.

#### 2) Examine and Compare Different Machine Learning Algorithms

This process is about making a general assessment of different machine learning algorithms which are suitable to solve the given task to shortlist potential algorithms for a final selection. When dealing with a new problem, it is needed to decide which group or class of algorithms is suitable to work with the problem and which is not.

This process is vital to prevent an over-generalizing decision to use algorithms which the researcher worked with before, in order to save the research and development time, rather than considering a well needed thorough selection process in favor of other approaches, which could be more suitable to solve the problem.

## V. RESULTS

The investigated model of this study shows that the Simulink environment has the ability to implement fault injection methods in the model and capture the measured data for further monitoring and analysis such as fault detection and diagnostics. The other effects of fault injection such as increase of energy consumption and operation cost of the heating system for each



zone can be calculated by putting a constant gain after the heater gain block in the heater subsystem. There are several methods for FDD, but this study highlights the potential of applying machine learning methods and proposes a step-by-step workflow for selection and data pre-processing.

Figure 7 shows the indoor CO<sub>2</sub> concentration based on the occupancy and damper status in healthy mode and faulty mode of a CO<sub>2</sub> sensor fault. In healthy system mode (green color signal), the open position of the damper is more frequent in more populated times. As a result, the damper status could remain closed in the rest and it prevents the coming of low-temperature excess air from the outside into the building (potential energy saving). The frequency of damper switching also depends on the size. It can be seen that in the faulty mode (red color signal), the heater will remain in the on position, and more energy will be consumed by the system.

The double y-axes figure 8 shows the room number one temperature variation based on the outside temperature variation, heating system and damper status in healthy mode (green color) and faulty mode (black color) of the system for different fault cases. Heater and damper are considered to have two possible values of one and zero that value one for the heater means the status on and for the damper means the position open and zero for heater means the status off and for the damper means the position close.

### CONCLUSION

This paper has presented a fault injection framework in a demand-controlled and heating system that is used for evaluation of fault detection and diagnosis techniques especially machine learning method. Several problems such as system failure or performance degradation can arise due to faults in each component such as a sensor fault including wrong sensor readings or noisy sensors, and actuator faults such as a stuck damper actuator or a stuck heater actuator in DCV systems. The model has the ability to represent the effect of fault injection on just two possible statuses, on: 1 or off: 0, and open: 1 or close: 0. different parameters in one room and also in the adjacent rooms. The collected system result shows that faults can

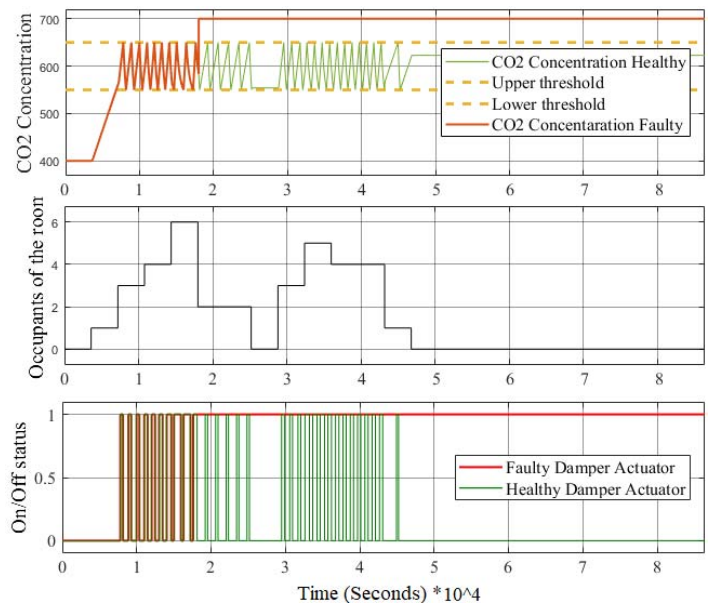

Fig. 7. Indoor CO<sub>2</sub> concentration based on the occupancy and damper status, in healthy mode (green color) and faulty mode (red color).

decrease the efficiency of the system due to its effect on the control components, that can contribute to energy consumption and operation cost increase. Further, implementing the presented machine learning selection workflow and selecting an individual, suitable learning solution has the potential to offer a learning FDD solution for the online detection of faults. How to practically apply the workflow for the presented system has to be highlighted in further studies and will enable further implications for the use of machine learning for fault diagnosis.

### ACKNOWLEDGEMENT

This work was supported by the DFG research grants LO748/11-1 and OB384/5-1.

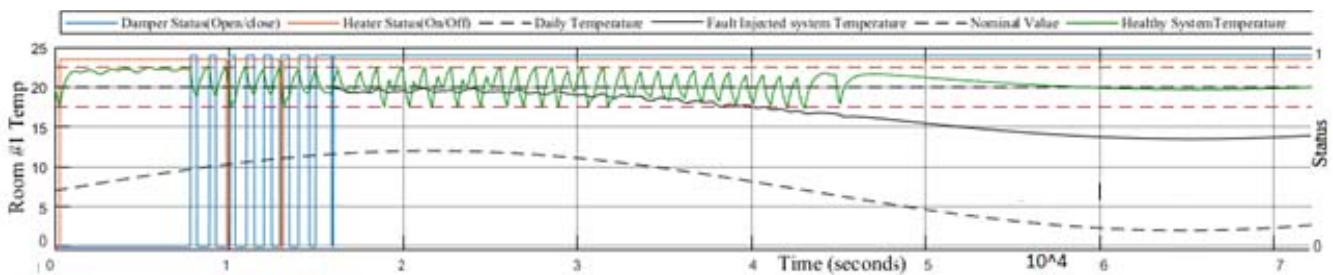

Fig. 8. The room number one temperature variation in healthy mode (green color) and faulty mode (black color) in case of activation CO<sub>2</sub> sensor fault.

## REFERENCES

- [1] K. Chinnakani, A. Krishnamurthy, J. Moyne, A. Arbor, F. Gu, "Comparison of Energy Consumption in HVAC Systems Using Simple ON-OFF, Intelligent ON-OFF and Optimal Controllers," 978-1-4577-1002-5/11/\$26.00 ©2011 IEEE.
- [2] U. S. D. o. Energy, "Commercial Energy End-Use Splits, by Fuel Type Quadrillion Btu," Building Energy Data Book, 2010.
- [3] S. Treado and Y. Chen, "Saving Building Energy through Advanced Control Strategies," *Energies*, 2013, vol. 6, pp. 4769-4785.
- [4] A. Persily, A. Musser, S. Emmerich, M. Taylor, "Simulations of indoor air quality and ventilation impacts of demand controlled ventilation in commercial and institutional buildings."
- [5] M. J. Brandenmuehl and J. E. Braun, "The impact of demand-controlled and economizer ventilation strategies on energy use in buildings," ASHRAE Transactions, 1999.
- [6] R. Isermann, "Fault-diagnosis systems," Springer-Verlag Berlin Heidelberg, 2006.
- [7] J. Hyvarinen, IEA Annex 25 Final Report, Volume I. VTT, Espoo, Finland, 1997.
- [8] S. Wu, "System-level monitoring and diagnosis of building HVAC system," Ph.D. thesis, University of California, Merced, 2013.
- [9] S. R. West, Y. Guo, X. R. wang, J. Wall, "Automated fault detection and diagnosis of HVAC subsystems using statistical machine learning," 12th conference of international building performance simulation association, Sydney, November 2011.
- [10] M. Basarkar, X. Pang, L. Wang, P. Haves, T. Hong, "Modeling and simulation of HVAC faults in EnergyPlus" 12<sup>th</sup> conference of international building performance simulation association, Sydney, November 2011.
- [11] J. Schein, S. T. Bushby, N. S. Castro, J. M. House, A rule-based fault detection method fo air handling units, *Energy and Buildings*, Vol. 38, 2006, pp. 1485-1492.
- [12] K. Bruton, P. Raftery, N. Aughney, M. M. Keane, D. O'Sullivan, "Development of an automated fault detection and diagnosis tool for AHUs," Proceedings of the 12<sup>th</sup> international conference for enhanced building operations, Manchester, UK, October 2012.
- [13] Lee, S. H., Yik, F. W. H. 2009. "A study on the energy penalty of various air-side system faults in buildings," *Energy and Buildings*, January 2010, pp. 2-10.
- [14] Katimapula, S., Brambley, M. R. "Methods for Fault Detection, Diagnostics, and Prognostics for Building Systems—A Review, Part I, HVAC&R Research," Volume 11, Issue 1, 2005, pp. 3 – 25.
- [15] Q. Zhou, S. Wang, Z. Ma, "A model-based fault detection and diagnosis strategy for HVAC systems," *International journal of energy research*, Vol. 33, February 2009, pp. 903-918.
- [16] G.H. Cibse, "Building Control Systems," Butterworth-Heinemann, Oxford, 2000.
- [17] B. Yu, D. H. C. van Paassen, "Fuzzy neural networks model for building energy diagnosis," 8<sup>th</sup> international IBPSA conference, Eindhoven, Netherlands, August 2003.
- [18] R. Sterling, G. Provan, J. Febres, D. O'Sullivan, P. Struss, M. M. Keane, "Model-based fault detection and diagnosis of air handling units: a comparison of methodologies," 6<sup>th</sup> international conference on sustainability in energy and buildings, *Energy procedia* Vol. 62, 2014, pp. 686-693.
- [19] S. Katipamula, M.R. Brambley, "Methods for fault detection, diagnostics and prognostics for building systems—a review," Part II, HVAC&R Research, Vol. 12, 2005, pp. 169–187.
- [20] J.M. House, W.Y. Lee, et al., Classification techniques for fault detection and diagnosis of an air-handling unit, *ASHRAE Transactions*, Vol. 105, 1999, pp. 1087–1097.
- [21] M. Abarkan, N. K. M'Sirdi, F. Ebrahimi, "Analysis and simulation of the energy behavior of a building equipped with RES in Simscape," *Energy procedia*, Vol. 62, 2014, pp. 522-531.
- [22] L.H. Chiang, E.L. Russell, et al., *Fault Detection and Diagnosis in Industrial System*, Springer-Verlag London Heidelberg Limited, London, 2001 (ISBN 1-85233-327-8).
- [23] Y. Yuebin, W. Denchai, Y. Daihong, "A review of fault detection and diagnosis methodologies on air-handling units," *Architectural Engineering, Digital Commons*, University of Nebraska, Faculty Publications, 2013, p. 85.
- [24] A. Smola, S.V.N. Vishwanathan, *Introduction to Machine Learning*, 2008.
- [25] A. Yezioro, B. Dong, F. Leite, An applied artificial intelligence approach towards assessing building performance simulation tools, *Energy and Buildings* 40, 2008, pp. 612-620.
- [26] A. Tsanas, J.Y. Goulermas, V. Vartela, D. Tsiapras, G. Theodorakis, A.C. Fisher and P. Sfirakis, The Windkessel model revisited: a qualitative analysis of the circulatory system, *Medical Engineering and Physics*, 2009, pp. 581-588.
- [27] M. Najafi, D. M. Auslander, P. L. Bartlett, P. Havas, "Application of machine learning in fault diagnostics of mechanical systems," Proceedings of the world congress on engineering and computer science, San Francisco, USA October 2008.
- [28] A. Behravan, R. Obermaisser, A. Nasari, "Thermal dynamic modeling and simulation of a heating system for a multi-zone office building equipped with demand controlled ventilation using MATLAB/Simulink," International conference on circuits, system and simulation, London, United Kingdom, July 2017, Conference proceeding pp. 103-108. IEEE.
- [29] I.H. Witten, E. Frank and M.A. Hall, *Data Mining – Practical Machine Learning Tools and Techniques* 3rd ed. Elsevier Inc. 2010.
- [30] S. Idowu, C. Ahlund, and O. Schelen, "Machine Learning in District Heating System Energy Optimization," 2014 IEEE Int. Conf. Pervasive Comput. Commun. Work Prog., 2014, p. 4.